



DS-712/DS-715

Serial-to-Ethernet Device Server

Features

- Incorporate Serial Devices in an Ethernet network
- Application Modes: Virtual COM, TCP Server, TCP Client
- Virtual COM supports 32-bit and 64-bit Windows 7 SP1/10/2012/2016
- High Performance Device Server
- Watchdog Timer suitable for use in harsh environments
- Power Reverse Polarity Protection
- Serial Port +/-4 kV ESD Protection Circuit
- Built-in High Performance MiniOS7 from ICP DAS
- Low power consumption
- 10/100 Base-TX Ethernet, RJ-45 Port (Auto-negotiating, auto MDI/MDI-X, LED indicator)
- Palm-Sized



Introduction

The DS-700 is a series of Serial-to-Ethernet Device Servers that are designed for linking RS-232/422/485 devices to an Ethernet network. By using the VxComm Driver/Utility, the built-in COM port of the DS-700 series can be virtualized to a standard PC COM port in Windows. By virtue of its protocol independence, a small size and flexibility, the DS-700 series meets the demands of virtually any network-enabled application.

The DS-712 is equipped with a male DB-9 connector and supports a 5-wire RS-232 port, while the DS-715 is equipped with a removable terminal block connector and supports a 4-wire RS-422 port or a 2-wire RS-485 port with 2000 Vrms isolation.

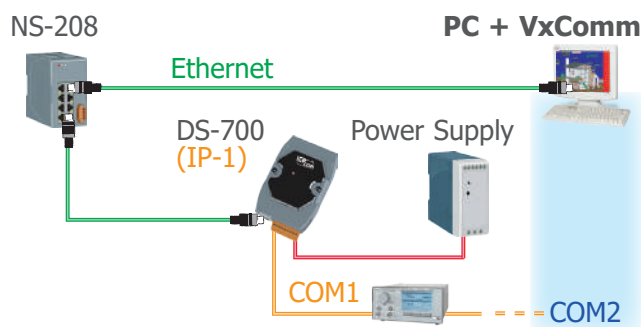

System Specifications

Models	DS-712	DS-715
CPU		
CPU	80186, 80 MHz or compatible	
Built-in Watchdog Timer	Yes	
Communication Interface		
COM1	Non-isolated	RS-232 (TxD, RxD, RTS, CTS, GND)
	Isolated (2000 Vrms)	–
	–	RS-422 (TxD+, TxD-, RxD+, RxD-); RS-485 (D+, D-)
Ethernet	10/100 Base-TX, RJ-45 port (Auto-negotiating, auto MDI/MDI-X, LED indicator)	
COM Port Formats		
Data Bit	7, 8	
Parity	None, Even, Odd, Mark, Space None parity is required when using 8 data bits and 2 stop bits.	
Stop Bit	1, 2	
Baud Rate	115200 bps max.	
LED Indicators		
L1	Run (Red)	
L2	Link/Act (Red)	
L3	10/100M (Orange)	

Models	DS-712	DS-715
Power		
Protection	Power Reverse Polarity Protection	
Required Supply Voltage	+12 Vdc ~ +48 Vdc (non-regulated)	
Power Consumption	2.0 W	
Mechanical		
Dimensions (W x L x H)	72 mm x 35 mm x 118 mm	72 mm x 35 mm x 124 mm
Installation	DIN-Rail or Wall mounting	
Environment		
Operating Temperature	-25 °C ~ +75 °C	
Storage Temperature	-40 °C ~ +80 °C	
Humidity	5 ~ 90% RH, non-condensing	

Pin Assignments

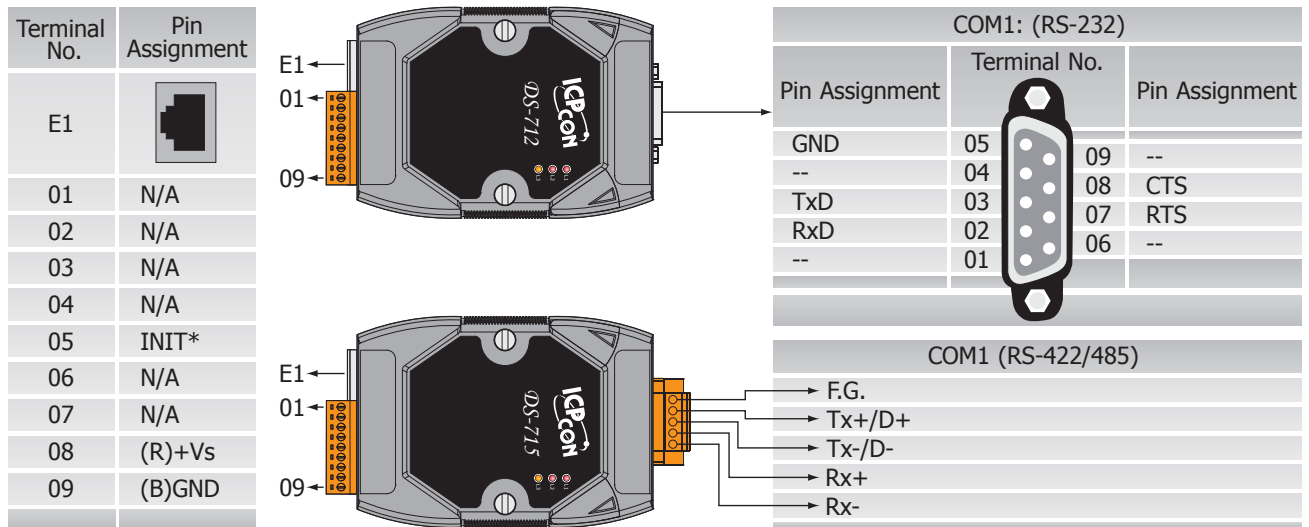

Dimensions (Units: mm)

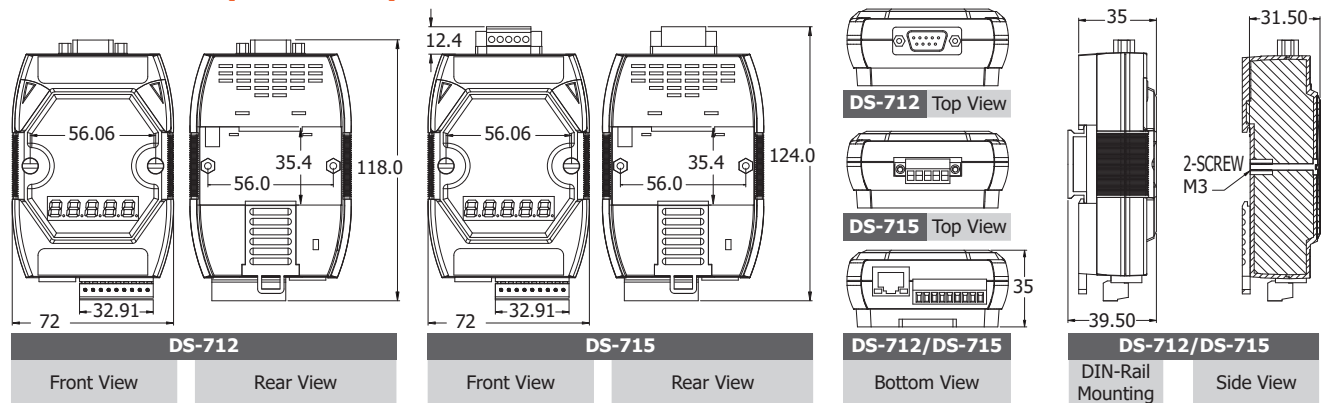

Ordering Information

DS-712 CR	Serial-to-Ethernet Device Server with 1-port RS-232 (RoHS)
DS-715 CR	Serial-to-Ethernet Device Server with 1-port Isolated RS-422/485 (RoHS)

Accessories

GPSU06U-6 CR	Power Supply, 110~240 VAC to 24 Vdc/0.25 A, 6 W, two pins USA plug (RoHS)
NS-205 CR	Unmanaged 5-port Industrial Ethernet Switch (RoHS)
NS-205PSE CR	Unmanaged 5-port 10/100 Mbps PoE (PSE) Ethernet Switch (RoHS)
DN-09-2F CR	Two Male DB9 to Screw Terminal Board (Pitch= 5.08 mm) with DIN-rail Mounting (RoHS)